

Data Sheet

Customer:

Part No: CL-SFC609USO-01

Sample No: _____

Description: 5630 Orange SMD

Item No: _____

| Customer | | | |
|----------|------------|----------|------|
| Check | Inspection | Approval | Date |
| | | | |

Features:

- . Reflow Solderable
- . High Luminous Intensity and Low Power Dissipation
- . Good Reliability and Long Life
- . Complied With RoHS Directive

Applications

- Optical indicator
- Indoor display
- Backlighting in dashboard and switch
- Flat backlighting for LCD, symbol and display
- General use

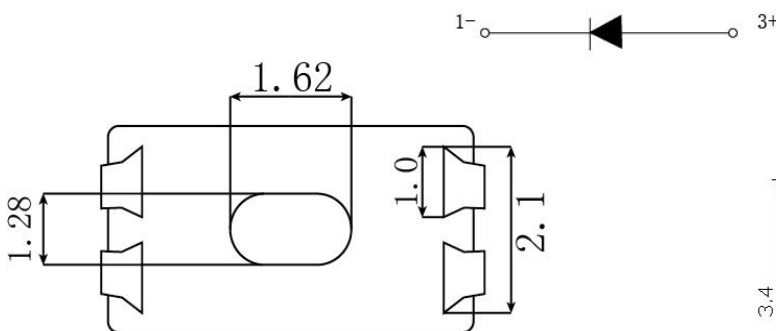
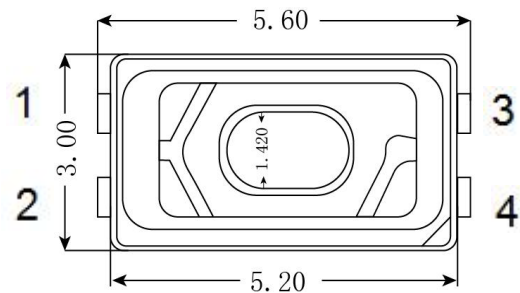
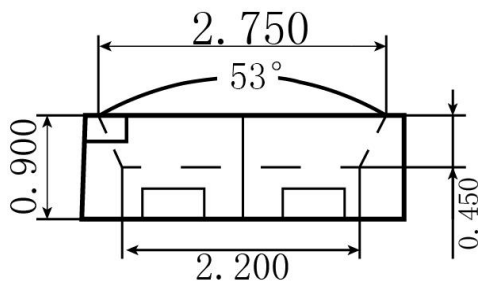

Recommended Soldering Pattern:
(Units : mm)

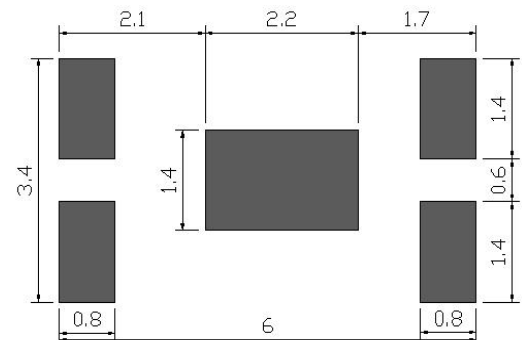
Notes:

- 1 . All dimension units are millimeters.
2. All dimension tolerance is $\pm 0.2\text{mm}$ unless otherwise noted.

Selection Guide

| Part No. | Chip Materials | Lens Type | Luminous Flux(Lm) @90mA | | | Viewing Angle |
|-----------------|----------------|-----------------|-------------------------|-----|-----|---------------|
| | | | Min | Typ | Max | 201/2 |
| CL-SFC609USO-01 | InGaN | Yellow Diffused | 30 | -- | 40 | 120 |

Note:

- 1.201/2 is the angle from optical centerline where the luminous intensity is 201/2 the optical centerline value.
- 2.The above luminous intensity measurement allowance tolerance $\pm 10\%$

Electrical / Optical Characteristics at Ta=25°C

| Parameter | Symbol | Min. | Typ. | Max | Units | test conditions |
|---------------------|-------------|------|------|-----|-------|-----------------|
| Forward Voltage | VF | 2.8 | -- | 3.4 | V | IF=90mA |
| Reverse Current | IR | -- | -- | 10 | uA | VR = 5V |
| Dominate Wavelength | λ_d | 600 | -- | 610 | nm | IF=90mA |

Absolute Maximum Ratings at Ta=25°C

| Parameter | Symbol | Rating | Units |
|--------------------------|--------|----------|-------|
| Power Dissipation | Pd | 306 | mW |
| DC Forward Current | IF | 90 | mA |
| Peak Forward Current [1] | IFP | 150 | mA |
| Reverse Voltage | VR | 5 | V |
| Operating Temperature | Topr | -40~+85 | °C |
| Storage Temperature | Tstg | -40~+100 | °C |

Note:

1. 1/10 Dut cycle,0.1ms pulse width.
2. The above forward voltage measure ment allowance tolerance $\pm 0.1V$.

Typical optical characteristics curves

Ambient Temperature VS. Forward Current

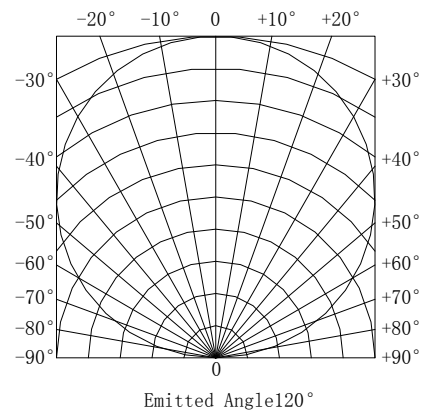
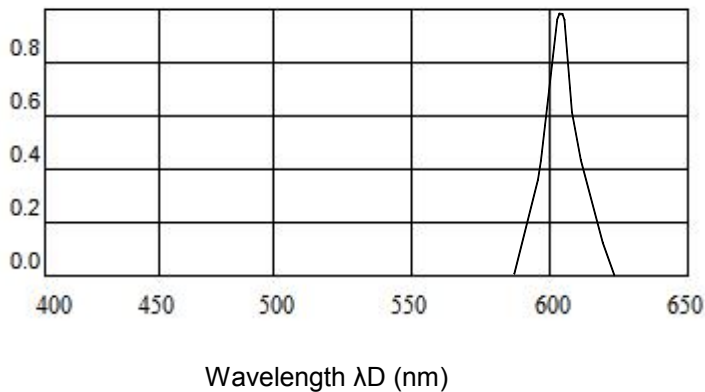
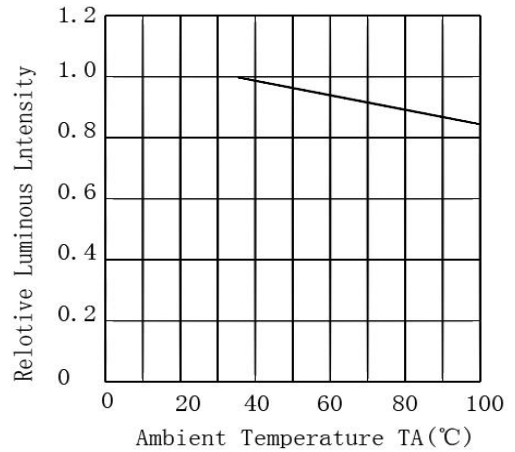
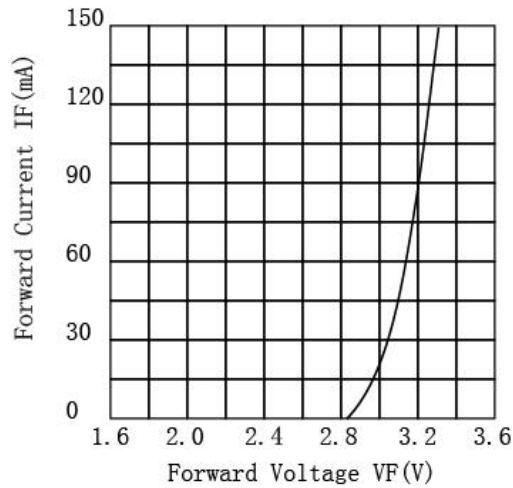
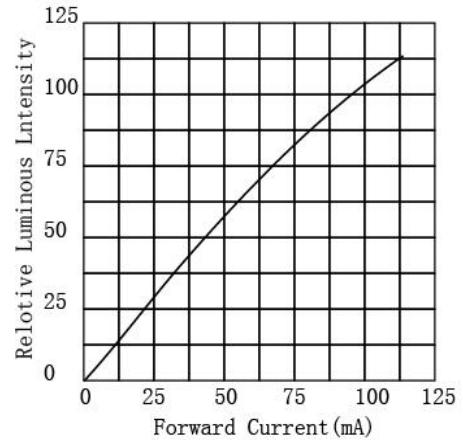
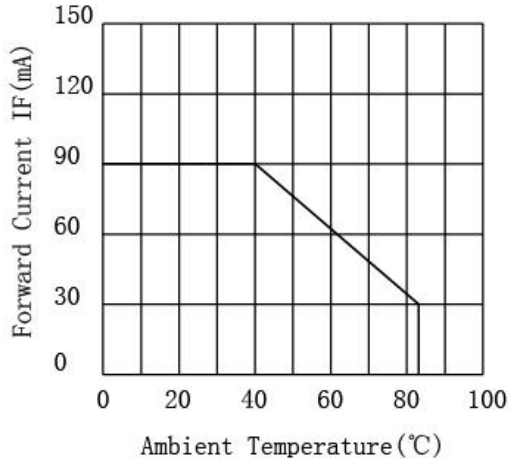

Reliability Test Items And Conditions

| Test Items | Ref.Standard | Test conditions | Time | Quantity | Ac/Re |
|--|--------------|---|------------|----------|-------|
| Reflow | JESD22-B106 | Temp:260°C max T=10 sec | 3 times. | 22Pcs. | 0/1 |
| Temperature Cycle | JESD22-A104 | 100°C±5°C 30 min. ↑↓5 min -40°C±5°C 30 min. | 100 Cycles | 22Pcs. | 0/1 |
| High Temperature Storage | JESD22-A103 | Temp:100°C±5°C | 1000Hrs | 22Pcs. | 0/1 |
| Low Temperature Storage | JESD22-A119 | Temp:-40°C±5°C | 1000Hrs | 22Pcs. | 0/1 |
| Life Test | JESD22-A108 | Ta=25°C±5°C IF=90mA | 1000Hrs | 22Pcs. | 0/1 |
| High Temperature High Humidity Life Test | JESD22-A101 | 85°C±5°C/ 85%RH IF=90mA | 1000Hrs | 22Pcs. | 0/1 |

Criteria For Judging Damage

| Test Items | Symbol | Test conditions | Criteria For Judgement | |
|--------------------|--------|-----------------|------------------------|-------------|
| | | | Min. | Max. |
| Forward Voltage | VF | IF=90mA | | U.S.L*)x1.1 |
| Reverse Current | IR | VR = 5V | | U.S.L*)x2.0 |
| Luminous intensity | IV | IF=90mA | L.S.L*)x0.7 | |

U.S.L: Upper standard level

L.S.L: Lower standard level

The technical information shown in the data sheets are limited to the typical characteristics and circuit examples of the referenced products.It does not constitute the warranting of industrial property nor the granting of any license.

SMT Reflow Soldering Instructions SMT

1. For secondary high temperature welding, please complete within 168 hours.
2. When soldering, do not put stress on the LEDs during heating.

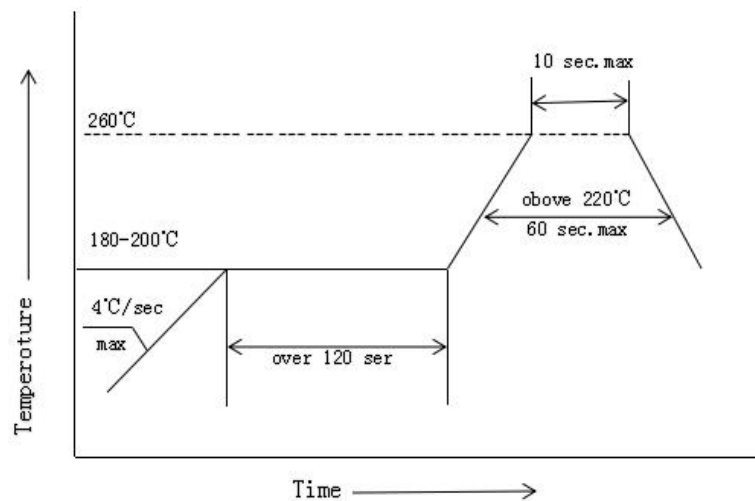

Soldering iron

1. When hand soldering, the temperature of the iron must be less than 315°C for 3 seconds.
2. The hand solder should be done only one time.

Repairing

Repair should not be done after the LEDs have been soldered. When repairing is unavoidable, a double-head soldering iron should be used (as shown in the figure below). It should be confirmed in advance whether the characteristics of LEDs will or will not be damaged by repairing.

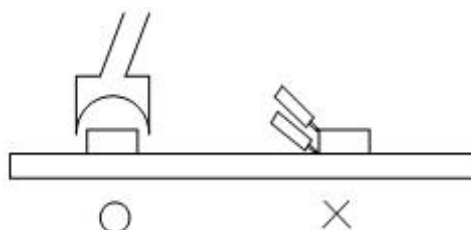

Storage

This product uses sealing anti-moisture antistatic packaging, and with desiccant, humidity card.

Before packaging is opened:

- 1、 The storage environment is: the ambient temperature should be maintained between 5 °C and 30 °C, and the relative humidity should be maintained within 60 % RH. When the storage time of the product exceeds 6 months, the product must be rebaked for use.
- 2、 Please check that the package is leaking before opening. If it has leaked, please re-bake and use it or return to the plant to dehumidify.

After opening the package:

- 1、 After opening the package, check whether the humidity card has a discoloration phenomenon. For example, 30 % of the humidity card indicates discoloration. Please remove the material from the bag and use it after dehumidifying 24H at 65 °C.
 - 2、 Environmental conditions: The ambient temperature should be kept between ≤ 30 ° C and relative humidity
- The lower 60 % RH should be maintained.
- 3、 if the material is not produced after exposure in the workshop for more than 168hours, the product must be put back in the oven, dehumidified with 65 °C 24H, and then can be used again. If the material is not produced after 336 hours of exposure in the workshop, return the material to the SMD plant for high temperature dehumidification.

- 4、 When the material is dehumidified, please do not open the oven in the middle, so that the oven temperature will not drop to the dehumidification effect.

Please refer to the following operating methods when the material needs to be dehumidified



Correct way: material desiccant need to remove the bag, use the way of hanging baked

Wrong way: the material is dehumidified without removing the bag, in a stacking manner

ESD

Static Electricity will damage the LED.

The following steps can reduce the likelihood of ESD causing product damage

- 1.All productive machinery and test instruments must be electrically grounded.
- 2.Use a conductive wrist band or anti-electrostatic glove when handling these LEDs.
- 3.Maintain a humidity level of 50%RH or higher in production areas.
- 4.Use anti-static packaging for transport and storage.

Handling Precautions

- 1.Do not stack the assembled PCB together. This may scratch the surface of the product or damage the circuit.

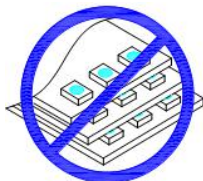

2. Not available in the situation of acidity for PH.



3. Electrostatic sensitive device



Carrier tape 3000PCS/REEL

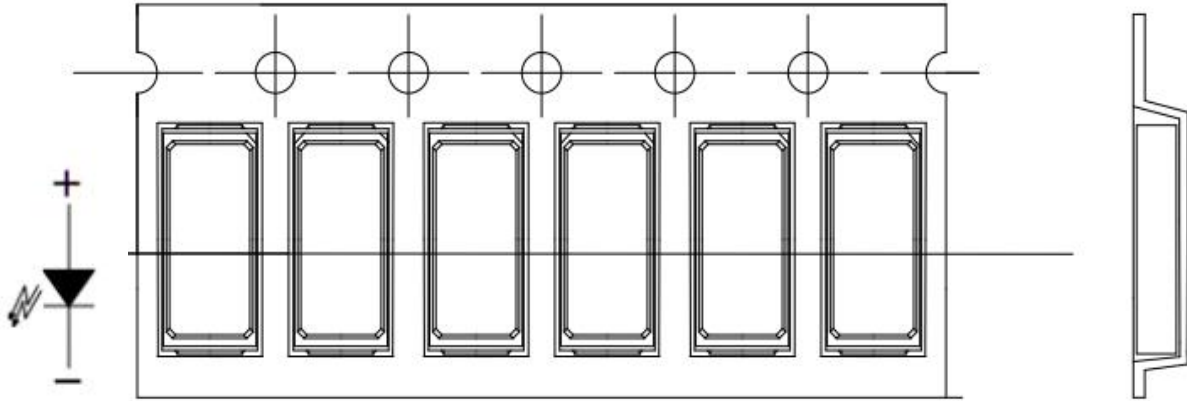

All dimensions in mm, tolerances unless mentioned is ± 0.1 mm.

Moisture Resistant Packaging

