

## Surface Mounted Chip LED

## SP155UHR

### ◆ Features :

- Compatible with automatic placement equipment
- Compatible with reflow solder process

### ◆ Applications :

- Automotive\_Telecommunication
- Indicators
- LCD Back-lights
- Illuminations

### ◆ Absolute Maximum Ratings

( Ta=25°C )

Item	Symbol	Maximum	Unit
Peak Forward Current(1/10 Duty Cycle 0.1ms Pulse Width)	I <sub>FP</sub>	100	mA
Reverse Voltage	V <sub>R</sub>	5	V
Derating Linear From 25°C		0.4	mA/°C
Operating Temperature Range	Topr	-40 to +85	°C
Storage Temperature Range	Tstg	-40 to +85	°C

### ◆ Electrical/Optical Characteristics

( Ta=25°C )

Chip			Lens Appearance	Absolute Maximum Rating			Electro-optical Data (At 20mA)				Viewing Angle 201/2 (deg)
Emitted Color	λ <sub>P</sub> (nm)	λ <sub>D</sub> (nm)		Δλ (nm)	P <sub>D</sub> (mW)	I <sub>Fmax</sub> (mA)	V <sub>F</sub> (V)		I <sub>v</sub> (mcd)		
							Typ.	Max.	Min.	Typ.	
Ultra High Red (Die 1)	645	631	Water Clear	20	78	30	2.1	2.6	45.0	72.0	120°
Ultra High Red (Die 2)	645	631		20	78	30	2.1	2.6	45.0	72.0	

※The measuring tolerance → Luminous intensity ±15%  
Wavelength (λ<sub>D</sub>) ±2nm

◆ Dimensions / Taping and Package Spec.

● Package Dimensions of Device ( SP155 Die1 Die2 Series )

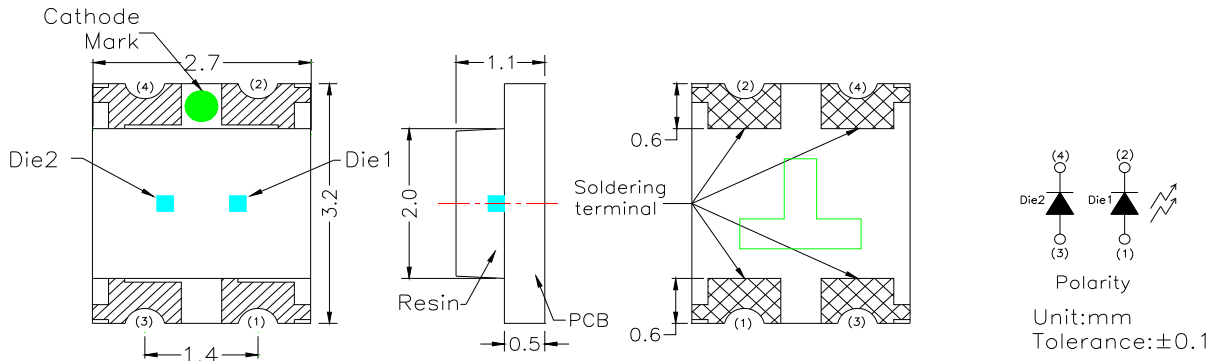

● Recommended Soldering Pad Dimensions

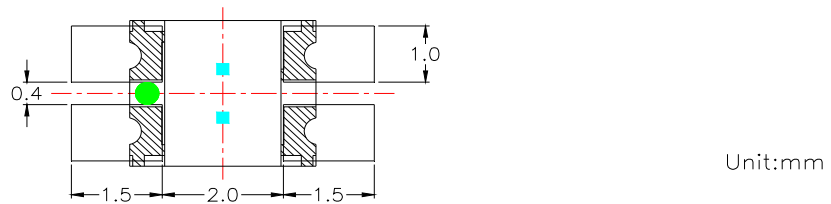

● Tape Specification : 3000pcs Per Reel

Packing Size													
Item	W	P1	E	F	Do	D1	Po	10Po	P2	Ao	Bo	Ko	t
Spec.	8.00	4.00	1.75	3.50	1.50	1.00	4.00	40.00	2.00	2.8	3.35	1.35	0.23
Tolerance	±0.20	±0.10	±0.10	±0.05	$^{+0.10}_{-0.00}$	±0.05	±0.05	±0.20	±0.05	±0.10	±0.10	±0.10	±0.05

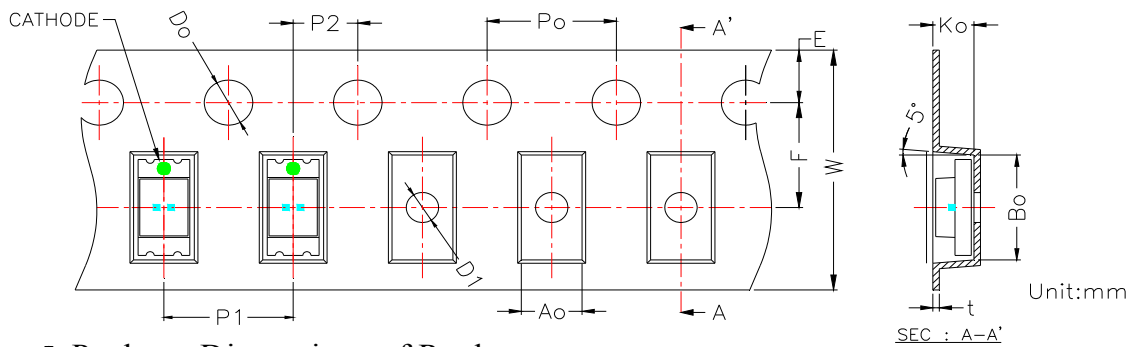

● Package Dimensions of Reel :

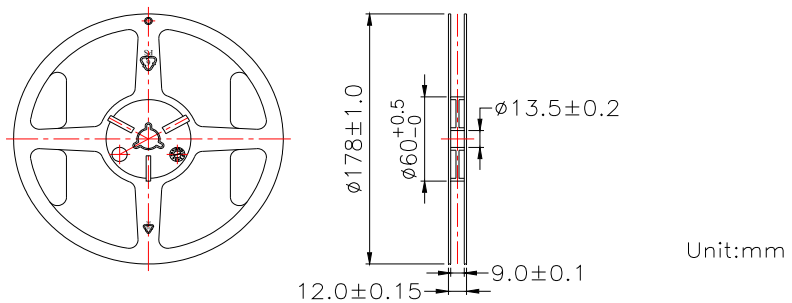

◆ **Typical Electro-Optical Characteristic Curves**  
**SP155UHR**

Forward Current Vs. Forward Voltage

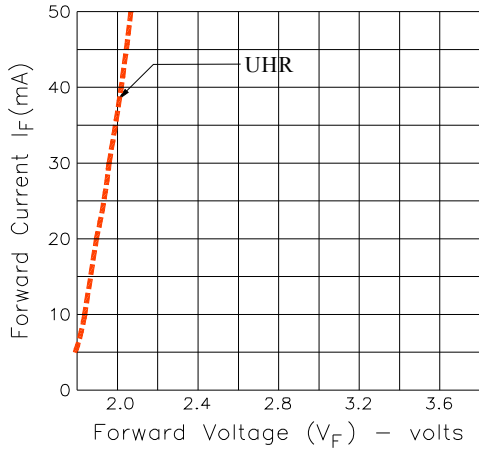

Luminous Intensity Vs. Forward Current

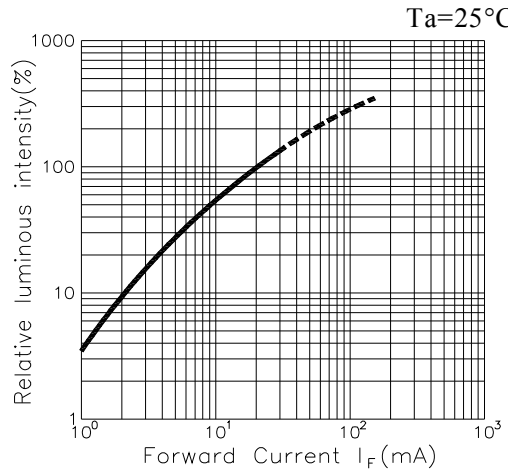

Forward Current Derating Curve

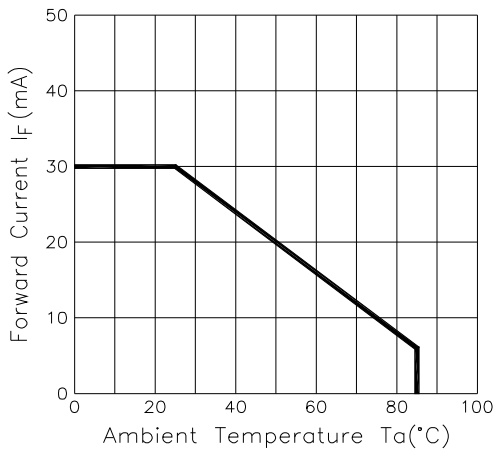

Radiation Diagram

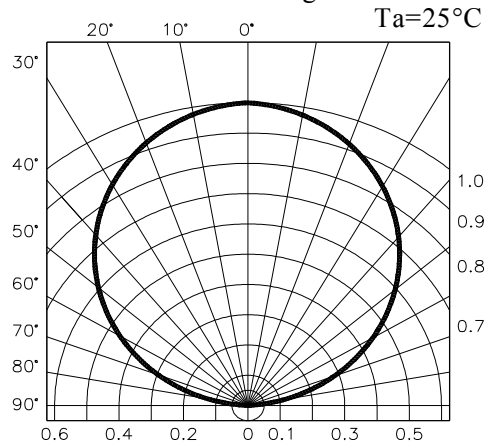

Spectrum Distribution

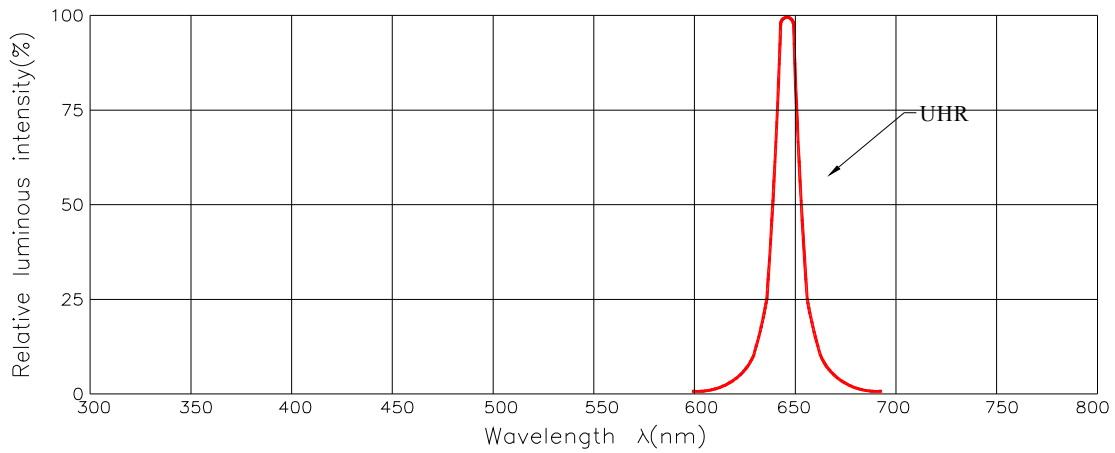

### ◆ Packing and Shipping Instruction

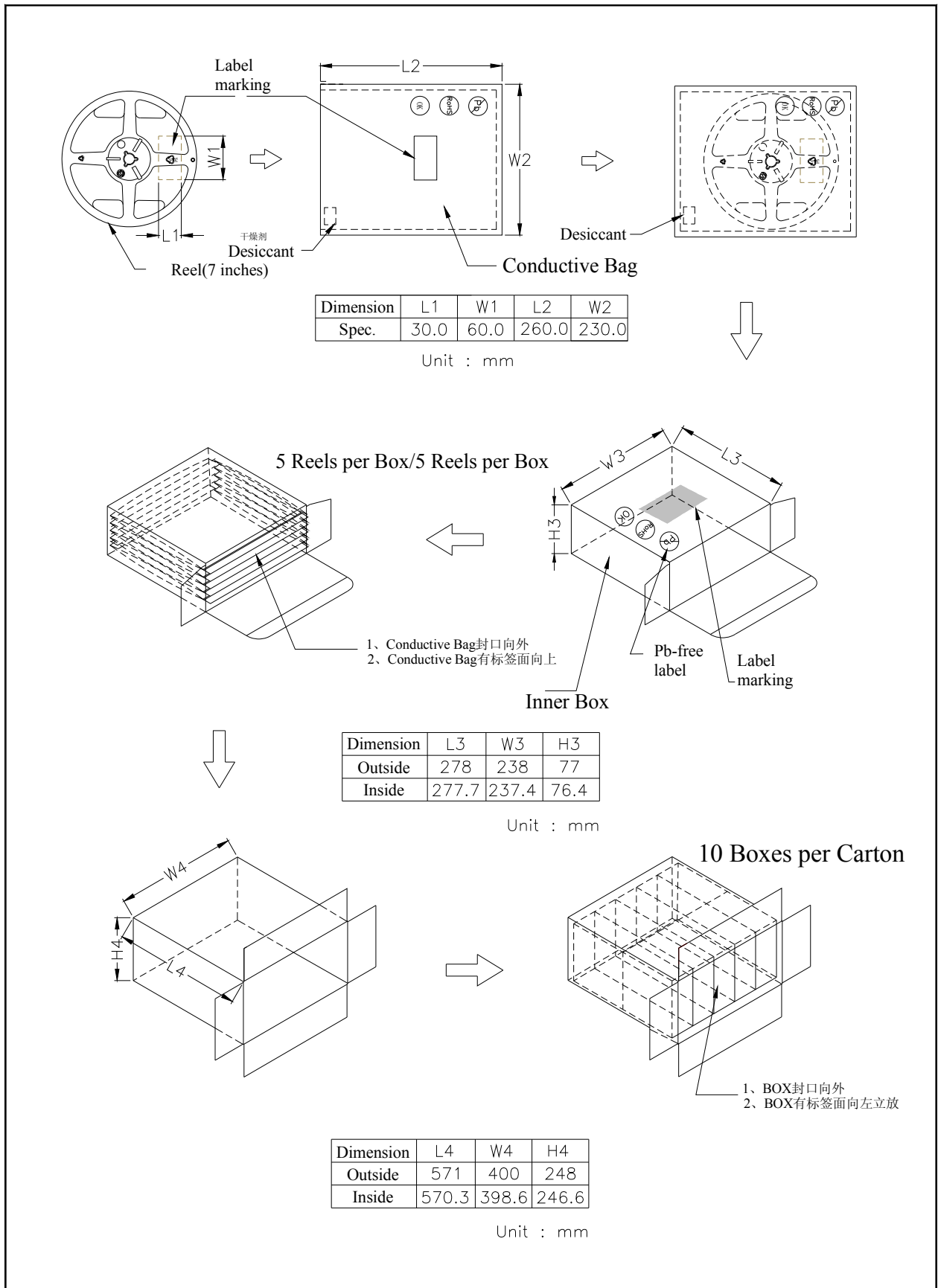

◆ **Descriptions :**

- The Chip-LED Taping is much smaller than lead frame type components, thus enable smaller board size, higher packing density, reduced storage space and finally smaller equipment to be obtained.
- Besides, lightweight makes them ideal for miniature application, etc.

◆ **Reliability Test Items And Conditions :**

No.	Item	Test Conditions	Test hr/cycle/time	Sample Q'ty	Ac / Re
1	Solder Heat	TEMP :260°C±5°C ;10±1 sec	2 times	30 pcs	0 / 1
2	Solderbility Test ※	TEMP :235°C±5°C ;3±1 sec	1 time	5 pcs	0 / 1
3	Temperature Cycle	H : +85°C 30min. ∫ 5min. L : -40°C 30min.	100 cycles	20 pcs	0 / 1
4	Thermal Shock	H : +85°C 5min. ∫ L : -40°C 5min.	50 cycles	20 pcs	0 / 1
5	High Temperature Storage	TEMP : 85°C	1000 hrs	20 pcs	0 / 1
6	Low Temperature Storage	TEMP : -40°C	1000 hrs	20 pcs	0 / 1
7	DC Operating Life	$I_F = I_{Fmax}$	1000 hrs	20 pcs	0 / 1
8	High Temperature High Humidity	85°C / 90~95%R.H.	1000 hrs	20 pcs	0 / 1
9	Shocking test	100~2000Hz ; 98.1m/s <sup>2</sup> X,Y,Z direction	2 hrs	20 pcs	0 / 1
10	Dropping test	Put on pallet ; height : 75cm	3 times	20 pcs	0 / 1
<b>Judgment Criteria</b>					
Forward Voltage $V_F$		$V_F$ Max-Increase < 1.1x			
Reverse Current $I_R$		$I_R$ Max-Increase < $I_{Rmax}$			
Luminous Intensity $I_V$		$I_V$ Decay < 40%			
※Tolerability test criteria : coverage is not less than 95%					
Note : Measurement shall be taken after the tested samples have been returned to normal ambient conditions (generally after two hours)					

◆ **Test Circuit**

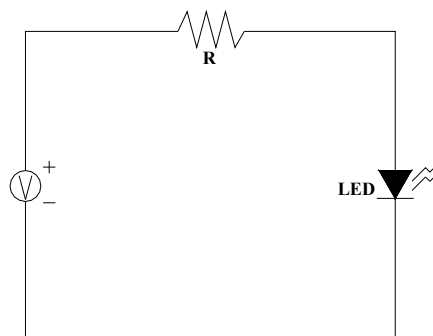

◆ **Precautions For Use :**

- Overdrive current proof  
Customer must apply resistors for protection, otherwise slight voltage shift will cause current change with great deal. ( Burn out will happen )
- Storage
  1. The operation of temperature and R.H. are : 5°C ~ 30°C , 60%R.H. Max..
  2. Once the package is opened, the products should be used within a week. Otherwise, they should be kept in a damp-proof box with desiccant. Considering the tape life, we suggest our customers to use our products within 1.5 year ( from production date ) .
  3. It's recommended to bake before soldering when the package is unsealed more than 72 hrs. The condition is : 60°C±5°C for 15hrs.

◆ **Reflow Temp. / Time :**

TEMP (°C)		TIME (sec)	
a	25	T0~T1	5°C/sec max
b	150	T1~T2	90~130
c	200	T2~T3	5°C/sec max
d	230	T3~T6	60~90
e	260	T4~T5	10±1
		T6~T7	-6°C/sec max
<b>MSL level</b>		<b>Level 4</b>	

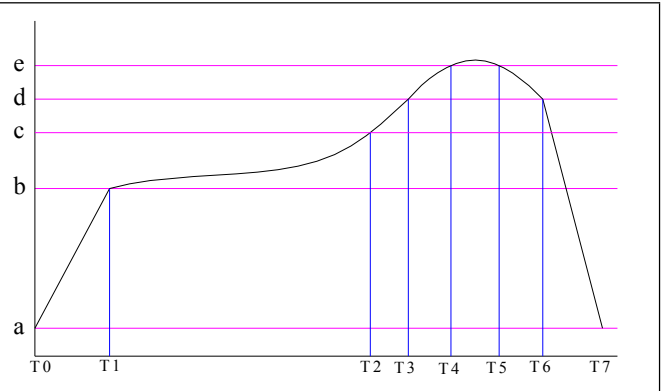

◆ **Hand Soldering Iron :**

- Temperature at tip of iron : 350°C Max. ( 35W Max. )
- Soldering time : 3 ±1sec.

◆ Numbering System : SMD LED

● Mono-Color :

1. ■■-□□□□□□□□□□□□□□ : **Company Code**
2. □□-■□□□□□□□□□□□□□ : **Product Code** : SMD→S、DIP→D
3. □□-□■□□□□□□□□□□□□ : **Structure Code** : PCB Type→P、L/F Type→L
4. □□-□□■■■■□□□□□□□□□□ : **Model Code** : 1206→150、0805→170,172、0603→190  
**1<sup>st</sup> Number(Package Code)** : Standard Type→1、Routing Type→2、Lens Type→3  
**2<sup>nd</sup> Number(Size Code)** : 1204 side-view→1、0402→2、0802 side-view→3、0803 side-view→4、1206→5、0603 side-view→6、0805→7、1104 side-view→8、0603→9、3Φ→A、5Φ→B、1205→C、1.6Φ→D  
**3<sup>rd</sup> Number (Type Code)** : 1 Chip→0、2 Chips→5、3 Chips→7
5. □□-□□□□□□■■■■□□□□□□ : **Color Code (2~3 Code)**
6. □□-□□□□□□□□□□■□□□□□ : **Internal Code**
7. □□-□□□□□□□□□□□□■□□□ : **Appearance Code** : Color Diffused→1、Color Transparent→2、White Diffused→3、Water Clear→4
8. □□-□□□□□□□□□□□□□□-■■■ : **Assistant Code(0~6 Code)**

● Multi-Color

1. ■■■-■■■■■■■■□□□□□□□□□□□□ : **The Same With The Mono-Color Type**
2. □□-□□□□□□■■■■■■■■■□□□□□□ : **Color Code(4~6 Code)**
3. □□-□□□□□□□□□□□□□□■□□□□□ : **Appearance Code** : White Diffused→3、Water Clear→4
4. □□-□□□□□□□□□□□□□□□□-■■■ : **Assistant Code(0~2 Code)**

**Model NO : SP155UHR**
**◆ Luminous Intensity BIN Limits**

BIN Code	Test condition : @20mA	
UHR	$I_{Vmin}$ (mcd)	$I_{Vmax}$ (mcd)
J	45	72
K	72	115
L	115	180

BIN Code	Test condition : @20mA	
UHR	$I_{Vmin}$ (mcd)	$I_{Vmax}$ (mcd)
J	45	72
K	72	115
L	115	180

**◆ Dominant Wavelength BIN Limits**

BIN Code	Test condition : @20mA	
UHR	$\lambda_{Dmin}$ (nm)	$\lambda_{Dmax}$ (nm)
1	624	640

BIN Code	Test condition : @20mA	
UHR	$\lambda_{Dmin}$ (nm)	$\lambda_{Dmax}$ (nm)
1	624	640

**◆ Label Marking**

Product NO :	(Model NO)
Lot NO :	
Quantity :	(Seal/Date) pcs
Q.C. :	BIN
Date :	(Date of Produce)